

Simplify PoE Implementation with Complete PD Interface and Integrated Switching Regulator

by Kirk Su

Introduction

IEEE 802.3af Power over Ethernet (PoE) is a standard for delivering power over Cat-5 cables, eliminating the need for AC-adapters for equipment plugged into the Ethernet. The two major components in a PoE system are Power Sourcing Equipment (PSE), which deliver power, and Powered Devices (PD), which receive and use the power. A PSE will not deliver power to the load unless it detects a valid signature resistance, which distinguishes a compliant PD from a device that cannot receive power. Once the PD receives power, it must also convert the -48V PoE efficiently to a suitable power supply voltage. Typical PD designs employ two ICs for these tasks. An obvious way to simplify PD designs would be to integrate the interface and DC-DC conversion circuitry into a single device.

The LTC4267 reduces the complexity and size of a PD by combining an IEEE 802.3af-compliant PD interface with a current mode switching regulator. Figure 1 shows a block diagram of the device. The LTC4267 includes the 25k Ω signature resistor, classification current source, thermal overload protection, signature disable and a power good signal, along with an under-voltage lockout (UVLO) optimized for use with the IEEE-required diode bridge. The precision dual-level current limit allows the LTC4267 to charge large load capacitors and interface with legacy PoE systems. The current-mode switching regulator is designed for driving a 6V rated N-channel MOSFET and features programmable slope compensation, soft start, and constant frequency operation, minimizing noise even with light loads. The LTC4267 includes an onboard error amplifier

and voltage reference allowing its use in both isolated and non-isolated configurations. All this functionality is packed into a space-saving, low-profile 16-pin SSOP or DFN package.

PD Implementation Made Simple

Figure 2 presents a complete PD detection and power conversion application—a testimony as to how simple a PD implementation can be. The LTC4267's package size is the smallest in the industry, and many of the circuits that are traditionally implemented with external components have been folded into this device.

During detection, the Power Sourcing Equipment (PSE) identifies the presence of an IEEE 802.3af-compliant PD by applying two voltages, measuring the corresponding current, then performing a $\Delta V/\Delta I$ calculation.

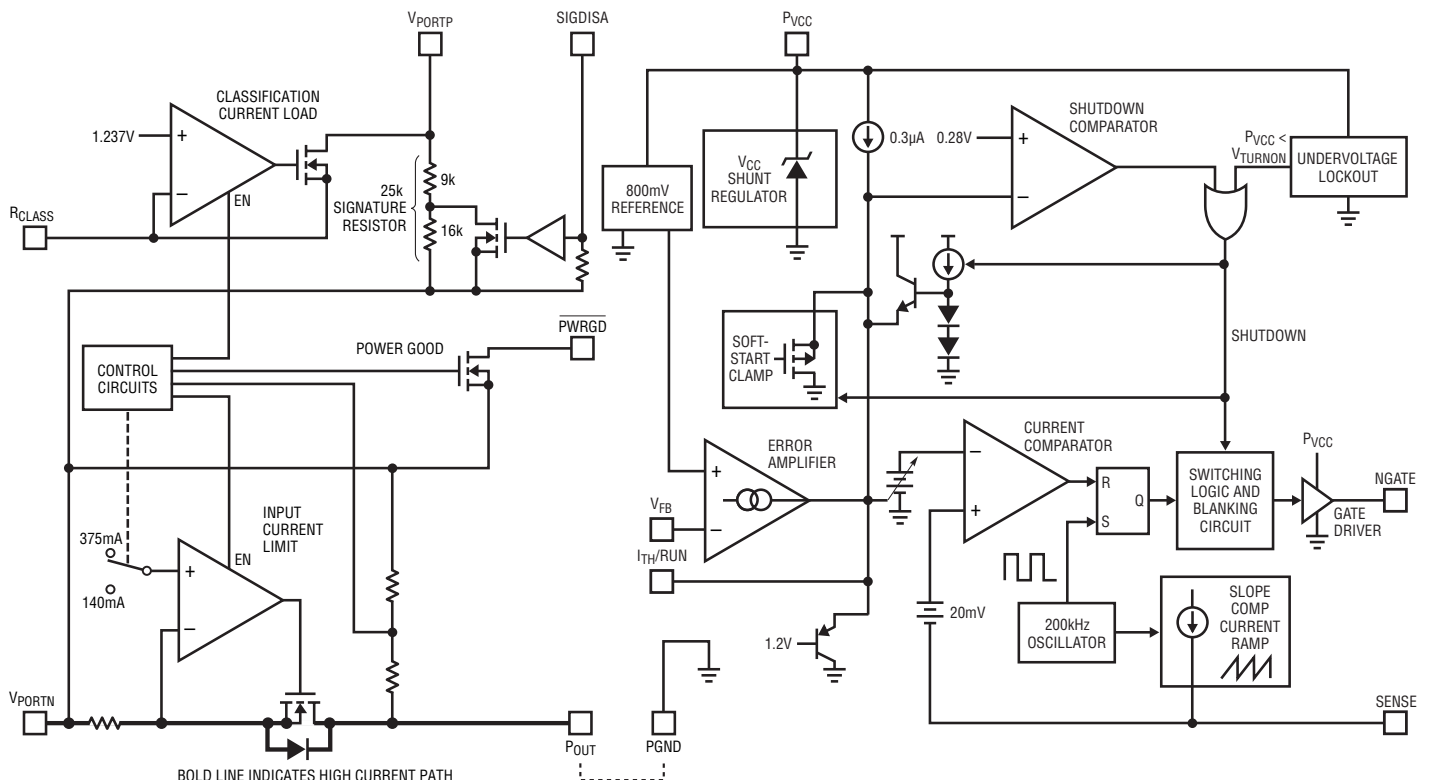

Figure 1. LTC4267 block diagram

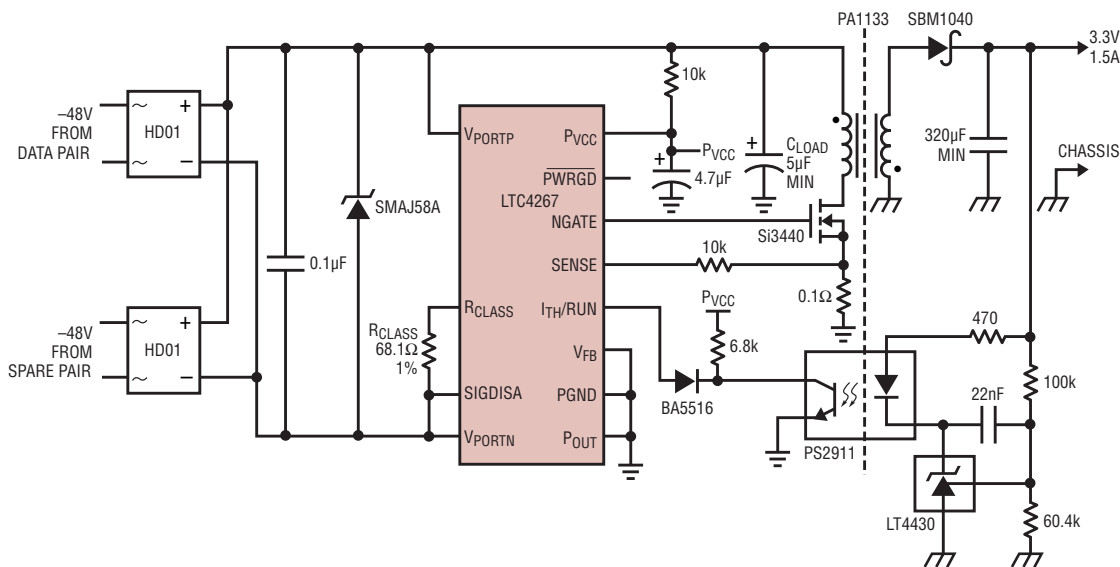

Figure 2. A Class 2 PD with 3.3V isolated power supply

A 25kΩ signature resistance signals the PSE that a valid PD is present and is ready to receive power. Most PD detection solutions require one or more external resistors to present a valid signature during detection. One of the benefits of the LTC4267 is an internal, temperature-compensated 25kΩ signature resistor, which is precision trimmed to account for the series resistance of the input diode bridges and all parallel leakage paths. This ensures proper PD detection without the need to size external components.

Another unique feature is the Signature Disable function. When the SIGDISA pin is exercised, the LTC4267 presents a 9kΩ resistance that signals the PSE not to power the PD. This feature simplifies the interface with an external power source such as a wall transformer.

Once the PSE detects the LTC4267, the PSE may classify the PD by detecting a range of load currents. The LTC4267 offers a simple scheme for PD classification: the PD designer programs the classification load current using a single R_{CLASS} resistor or leaves the R_{CLASS} pin open for class 0. During classification, the LTC4267 asserts a precision load current from the V_{PORTP} pin through the R_{CLASS} resistor to notify the PSE of the PD power requirements.

The IEEE 802.3af specifies the classification voltage range to be between -15.5V to -20.5V. However,

the LTC4267 is designed to remain in classification mode from -15.5V to the UVLO turn-on threshold of -36V nominal. IEEE 802.3af does not require this extended classification range, but the added range aids in the PSE-PD power-up stability by maintaining a monotonically increasing V-I characteristic up to the turn-on voltage.

The LTC4267 provides a complete and self-contained dual-current protection without the need for any external components. The LTC4267's unique current limit method ensures PD inter-operability with new and legacy PSEs, and unlike competing products, the LTC4267 does not depend on the PSE to monitor current limit. As the LTC4267 reaches the UVLO turn-on voltage and prepares to deliver power, the LTC4267 limits the inrush current to 140mA nominal until the load capacitor (C_{LOAD} in Figure 2) charges up to within 1.5V of the final value. Once this voltage threshold is reached, the current-limit threshold switches over to 375mA nominal for the remainder of the PD operation. The dual level current limit allows legacy PSEs with limited current sourcing capability to power up the PD while allowing the PD to maximize the power utilization from an IEEE 802.3af-compliant PSE. By maintaining a 375mA current limit once the PD is powered up, the LTC4267 keeps the PD from depending on the PSE for current limit and avoids possible

inter-operability problems. These current-limiting features are controlled by an onboard 100V, 400mA N-channel Power MOSFET and an internal sense resistor.

The LTC4267 presents a Power Good signal once the load capacitor (C_{LOAD} in Figure 2) is charged to within 1.5V of the final value. The Power Good signal may be used to signal to the switching regulator that the PD interface has charged up the load capacitor and is ready to apply power. A 3V hysteresis is included in the power good circuit, allowing the LTC4267 to operate near the current limit point without inadvertently presenting an invalid Power Good.

The thermal shutdown circuit monitors the die temperature, serving as an additional means of self-protecting the LTC4267 and other electronic circuitry from over-current or over-heating conditions. If such an event occurs in either the classification sequence (from the PSE probing exceeding the IEEE-mandated 75ms maximum) or in normal PD operations (from multiple turn on events), the thermal shutdown circuit protects the LTC4267 by disconnecting power to the output load and disabling the classification current until the die returns to a safe operating temperature.

Powering the LTC4267 switching regulator in the simplest case can be achieved with a dropping resistor between V_{PORTP} and P_{VCC}. An internal

shunt regulator maintains the supply at 9.4V, providing the required voltage needed for the gate drive. The LTC4267 can also be powered with a pre-regulator and/or with a separate bias winding on a flyback transformer. Each of these methods offer improved efficiency. The shunt regulator is particularly important when using a flyback methodology since it also serves the vital function of protecting the LTC4267 P_{VCC} pin from seeing too much voltage.

The LTC4267 switching regulator features two ways to enable operation during the initial power-up sequence. The P_{VCC} pin includes an UVLO circuit with hysteresis, and the I_{TH}/RUN pin serves as an enable as well as the compensation point for the internal error amplifier. Once the interface circuit charges the load capacitor, enable the switching regulator operation with the I_{TH}/RUN and P_{VCC} pin. Note that both pins must be enabled for operation to begin. The switching regulator may be disabled by either pulling the P_{VCC} pin below the UVLO turn-off threshold or by pulling the I_{TH}/RUN pin below the 0.28V nominal threshold.

Implementing a robust power-up sequence between the PD Interface circuit and the switching regulator is critical in a successful PD application. The power good signal indicates that the load capacitor is charged and this signal can be used to enable

the switching regulator. An N-channel transistor driven by \overline{PWRGD} can be used to disable the switcher by clamping the P_{VCC} or I_{TH}/RUN pins. Disabling the switching regulator until the load capacitor is charged up can also be accomplished with an RC delay on the P_{VCC} pin as shown in Figure 2. The flexibility of the LTC4267 provides the PD designer with the freedom of implementing a controlled power-up sequence in a variety of ways.

The LTC4267 features a soft-start feature that provides an additional 1.4ms delay once the I_{TH}/RUN pin is released. The soft-start feature reduces the switching regulator inrush current and reduces output overshoots. Unlike competing products, there is no minimum external capacitance required to program this delay. The designer may opt to provide additional soft-start delay by employing an external capacitor between I_{TH}/RUN and PGND pins.

An internal error amplifier with a precision voltage reference is integrated into the LTC4267. This feature is particularly desirable in non-isolated power supply applications since the PD designer does not need to add an external amplifier or reference. The internal precision reference provides output voltage accuracy to within $\pm 1.5\%$ over the 0°C to 70°C temperature range. For isolated power supply applications, the internal error amplifier and reference can be disabled by

connecting the VFB pin to PGND, and connecting an external error amplifier and opto-isolator to the I_{TH}/RUN pin. Figure 2 shows an example of an isolated power supply using an external amplifier and Figure 3 shows a non-isolated supply that uses the LTC4267's internal error amplifier.

Slope compensation is critical for stabilizing the control loop against sub-harmonic oscillations and is available on the LTC4267 by including an optional resistor between the sense resistor and the SENSE pin of the LTC4267. The SENSE pin monitors the voltage across the sense resistor. It also sources $5\mu\text{A}$ through the slope compensation resistor, raising the SENSE pin voltage above the sense resistor voltage. This in turn amends the duty cycle of the switching regulator, preventing sub-harmonic oscillation.

Conclusion

The LTC4267 is a self-contained Power over Ethernet PD interface that combines 802.3af PD classification with a switching regulator. It integrates many features that are traditionally implemented with separate components, but it retains the flexibility that external components offer. The result is a compact, easy-to-use, but versatile device. 

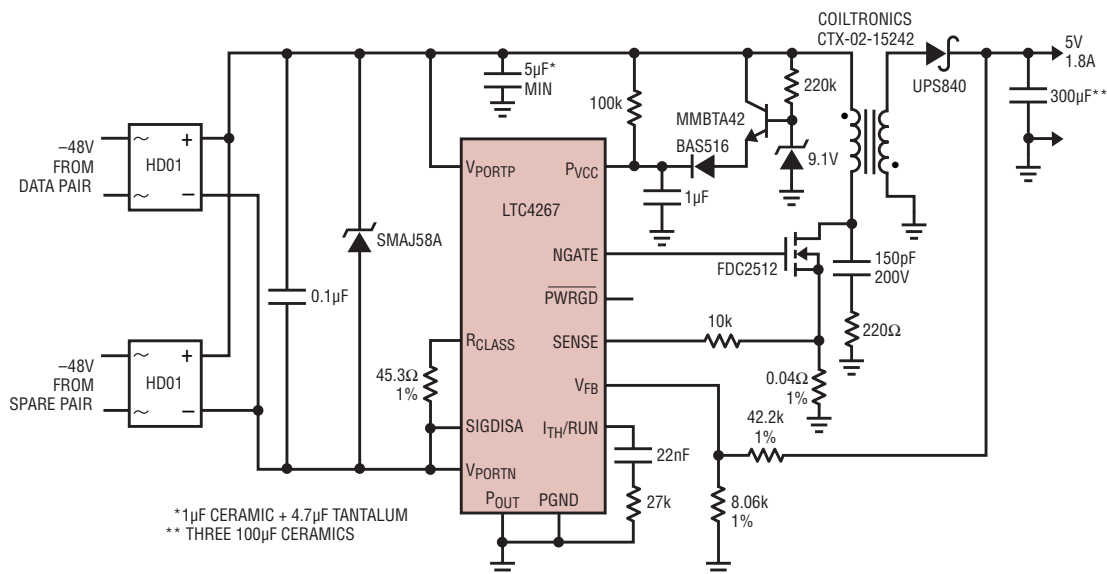

Figure 3. A Class 3 PD with 5V non-isolated power supply